

# OWNERS GUIDE TO INSTALLATION AND OPERATION

## SPM SERIES HIGH POWER CENTRIFUGALS

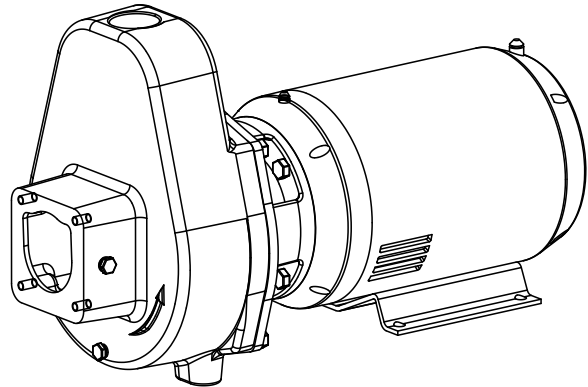

### READ THESE INSTRUCTIONS CAREFULLY

Read these installation instructions in detail before installing your pump.

Be sure to check the following:

1. Be certain the motor is connected for the correct line voltage being used (check motor nameplate).
2. Be certain the pump is completely primed before starting, otherwise damage may occur to the seal.

Every pump is tested before leaving the factory and its performance depends largely on the installation.

### GENERAL SAFETY INFORMATION

1. Follow all local electrical and safety codes, as well as the National Electrical Code (NEC) and the Occupational Safety and Health Act (OSHA).
2. Replace damaged or worn wiring cord immediately.
3. Do not kink power cable and never allow the cable to come in contact with oil, grease, hot surfaces, or chemicals.
4. Protect the power cable from coming in contact with sharp objects.
5. Be careful when touching the exterior of an operating motor - it may be hot enough to be painful or cause injury.
6. Make certain that the power source conforms to the requirements of your equipment.
7. Always disconnect power source before performing any work on or near the motor or its connected load. If the power disconnect point is out-of-sight, lock it in the open position and tag it to prevent unexpected application of power. Failure to do so could result in fatal electrical shock.
8. Do not handle the pump with wet hands or when standing in water as fatal electrical shock could occur. Disconnect main power before handling unit for ANY REASON!
9. Unit must be securely and adequately electrically grounded. This can be accomplished by wiring the unit to a ground metal-clad raceway system or by using a separate ground wire connected to the bare metal of the motor frame or other suitable means.
10. **⚠ WARNING** Risk of electric shock. This pump has not been investigated for use in swimming pool areas.
11. **⚠ WARNING** This product contains chemicals known to the State of California to cause cancer and birth defects or other reproductive harm.

NOTE: Pumps with the "CSA" mark are tested to UL standard UL778 and certified to CSA standard C22.2 No. 108.

## APPLICATION

This pump is suitable for installations where the vertical distance from the pump to the water level does not exceed 25 ft. In all installations, friction losses in the suction pipe must be taken into consideration.

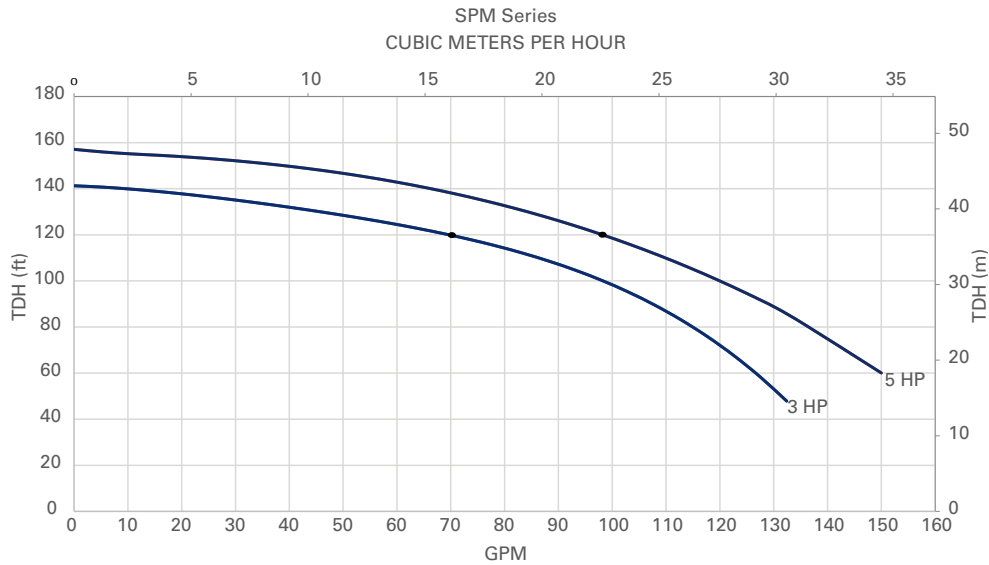

IL1932

## INSTALLATION

**PUMP LOCATION:** The pump should be installed in a clean, dry, and ventilated location which provides adequate drainage and room for servicing and protection from freezing temperatures. It should be bolted down evenly on a good foundation, preferably concrete, to prevent the development of unnecessary stress. Locating the pump as close as possible to the source of water supply reduces the friction losses in the suction pipe and provides for maximum capacities.

**SUCTION PIPE:** It is recommended that only new, clean pipe or hose be used, and the size be the same as that of the pump suction tapping. If the pump is installed any appreciable distance away from the source of water supply, the suction pipe should be increased by one size. The suction pipe must always slope upwards from the water source to the pump to avoid air pockets in the line. In cases where the pump has to be reprimed often and it is not necessary that a lot of water be delivered, it is advisable to use a 90° or 45° elbow on the suction line. This enables the pump to prime sooner and also prevents kinking of the hose. In cases where a maximum volume of water is required over a prolonged period of time, the suction line should be led almost horizontally to the pump. Non-toxic thread compound should be used on all pipe joints and connections should be thoroughly tightened. A strainer should be connected to the bottom end of the suction pipe and it should be well submerged at all times.

**WARNING: RISK OF ELECTRIC SHOCK.** Make sure the voltage and frequency of the power supply

agrees with that stamped on the motor nameplate. If in doubt, check with the power company.

### WARNING: ELECTRICAL PRECAUTIONS

ALL WIRING, ELECTRICAL CONNECTIONS AND SYSTEM GROUNDING MUST comply with the National Electric Code (NEC) and with any local codes and ordinances. Employ a licensed electrician.

**SINGLE PHASE:** Determine incoming voltage to motor. Where possible, use 230V. Connect wiring to terminal board located inside motor end cover. Be sure voltage connections agree with wiring diagram on motor nameplate.

**THREE PHASE:** Three phase motors require magnetic starters, and can run in either direction, depending on how they are connected to the power supply.

**TO CHECK FOR PROPER ROTATION:** Remove the motor end cover. This exposes the motor shaft. If hookup is correct, the shaft will rotate clockwise. If rotation is not clockwise, reverse any two leads to the starter. The rotation will now be correct.

### WARNING: RISK OF ELECTRICAL SHOCK

GROUNDING THE MOTOR: WIRING TO THIS PUMP MUST BE INSTALLED AND MAINTAINED IN ACCORDANCE WITH THE NATIONAL ELECTRIC CODE OR YOUR LOCAL ELECTRIC CODE. IF MORE INFORMATION IS NEEDED, CALL YOUR LOCAL LICENSED ELECTRICIAN OR YOUR POWER COMPANY.

It is recommended that a permanent ground connection be made to the unit using a conductor of appropriate size from a metal underground water pipe or a grounded lead in the service panel. Do

not ground to a gas supply line. Do not connect to electric power supply until unit is permanently grounded. Connect the ground wire to the approved ground and then connect to the terminal provided.

## OPERATION:

### PRIMING THE PUMP

**WARNING: DO NOT RUN THE PUMP BEFORE PRIMING. THE SEAL AND IMPELLER COULD BE PERMANENTLY DAMAGED.**

A priming plug is provided on suction flange kits 024912 and 024913. Once filled and the priming plug replaced, the pump will prime. If there is no flapper valve on the suction end, use a secondary priming above the discharge end. Again, once filled and the secondary plug/pipe is replaced, the pump will prime. Both situations require a foot valve to keep the pipe filled.

**CAUTION: DO NOT** run the pump before filling the pump case with liquid, as it may damage the seal.

**PRIMING UNDER PRESSURE: (FIGURE 1)** Should it be necessary to prime under pressure, place a check valve on the discharge line of the pump and a pet cock or a ball type air bleeder in place of the priming plug, or an air bleed line with a gate valve connected to the discharge line. It will then be possible for the liquid to remain in the discharge pipe and allow the pump to bleed off the remaining air, thereby facilitating priming.

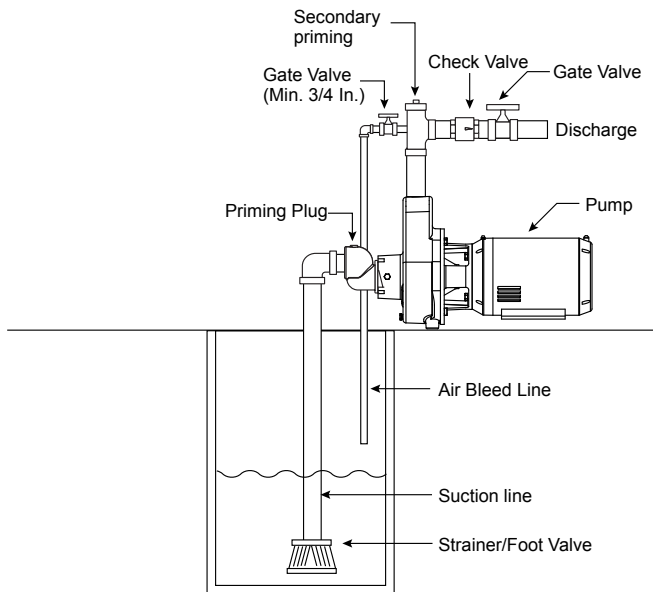

FIGURE 1

**IMPELLER ROTATION:** The impeller must rotate in a counter-clockwise direction as seen facing the pump from the front of the casing. In the event of wrong rotation for electric motor models, refer to the instructions furnished with the motor. The rotation of three phase motors can be changed by interchanging any two lead wires.

**STARTING THE PUMP:** Never operate the pump dry, as this may damage the seal. If an exceptionally long suction line is used, the water in the pump casing may become overheated or vapor locked. Should this occur, replace the water in the casing with cold water and continue priming.

**DRAINING:** Should the pump be subject to freezing temperatures, it will be necessary to drain the pump completely. To drain, remove the drain plug located at the bottom of the front face of the pump casing and the priming plug and make sure that the drain hole is not restricted. After all the water has been drained, operating the pump for a few seconds will ensure that the impeller is devoid of water. (Make sure that the suction line is also devoid of water.)

**STORAGE OF PUMP:** Drain liquid from pump to prevent freezing. It is recommended that a good rust inhibitor be put in the liquid end to prevent excessive corrosion. Be sure motor is kept dry and covered. When restoring the use of the pump, replace all plugs and make sure all connections are tightly sealed. After a complete check is made, make the initial prime according to directions under **PRIMING THE PUMP.**

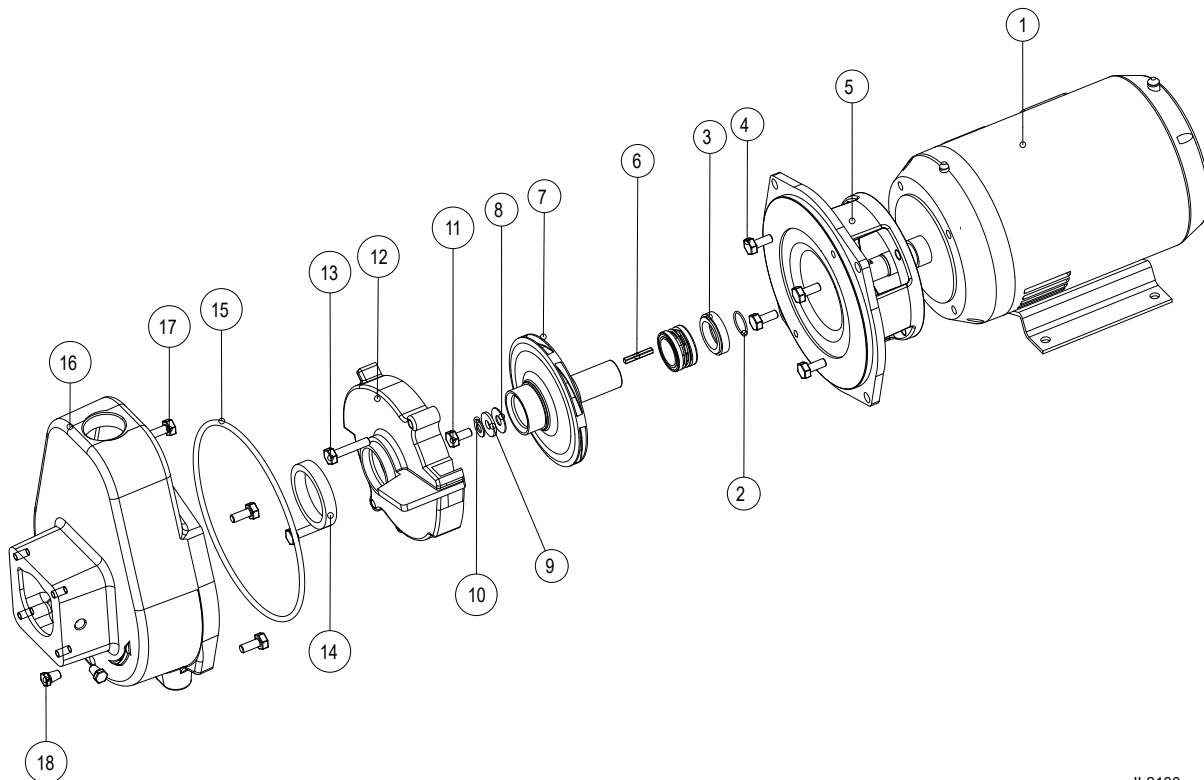

IL2100

**FIGURE 2**

**MAINTENANCE:**

**WARNING - ELECTRICAL PRECAUTIONS**

All wiring, electrical connections, and system grounding must comply with the National Electric Code (NEC) and with any local codes and ordinances. Employ a licensed electrician.

**WARNING: - RISK OF ELECTRICAL SHOCK**

Have an electrician provide electrical power to the motor.

Motor must be grounded and terminal cover in place to reduce electrical shock hazard.

Keep motor operating area as dry as possible.

A ground fault interrupter (GFI) protected circuit is recommended for use with any electrical device operating near water.

Always disconnect power before servicing.

Not investigated for use in swimming pool areas.

**LUBRICATION:** The pump requires no lubrication. For electric motor models, refer to instructions provided by the motor manufacturer.

**REPLACING THE MECHANICAL SEAL (FIGURE 2)**

**TO DISASSEMBLE:**

- a. Remove the bolts (17) and remove the casing (16).
- b. Remove the bolts (13) and remove the diffuser (12)
- c. Remove the impeller (unscrew impeller or remove retaining bolt, depending on the model).
- d. Slip the seal (3) off the impeller and/or mounting ring (5).
- e. Seat seal together (7) for replacement.

**TO REASSEMBLE:**

- a. Clean all parts thoroughly.
- b. Wet the rubber part of the seal seat with soap solution and press it into its housing in the seal plate or adapter, smooth ceramic surface facing outwards.
- c. Assemble the seal plate or adapter to the motor.
- d. Lubricate the seal with water or alcohol-based lubricant and slip it into the impeller sleeve. Make sure the sealing face is towards the ceramic seat. Clean the ceramic faces with lint-free towel.
- e. Replace the impeller.
- f. Reassemble to the casing and diffuser ring.
- g. Reconnect the suction and discharge piping and reconnect the electrical wiring.

**PRECAUTIONS:**

Whenever pump is dismantled and then reassembled, always check to see that the impeller rotates freely within the casing.

## TROUBLESHOOTING

PROBLEM	POSSIBLE CAUSE	CORRECTIVE ACTION
Failure to pump	1. Pump not properly primed.	1. Make sure pump casing and suction line are full of water. See PRIMING THE PUMP.
	2. Speed too low.	2. Check voltage at motor terminals and at meter when pump is operating. If low, refer to wiring instructions or check with your power company. Check for loose connections.
	3. Total head more than pump specifications.	3. Replace with pump designed for higher head.
	4. Suction lift is too great.	4. Locate pump closer to source of water. Make sure suction piping is large enough.
Reduced capacity and/or head	1. Air pockets or leaks in suction line.	1. Check suction piping.
	2. Clogged impeller.	2. Remove and clean impeller.
	3. Strainer too small or clogged.	3. Use larger strainer or clean.
	4. Insufficient submergence of suction line.	4. Add lengths of suction pipe to keep submerged end well below the water surface.
	5. Excessive suction lift.	5. If caused by suction pipe friction, enlarge piping. Otherwise, move pump closer to water level.
	6. Total head more than pump specifications.	6. Replace with pump designed for higher head.
	7. Excessively worn impeller.	7. Replace impeller.
Pump loses prime	1. Air leaks in suction line.	1. Check suction piping.
	2. Excessive lift and operating too near shut-off point.	2. Move pump closer to water level.
	3. Water level drops while pumping, uncovering suction piping.	3. Check water supply. Add length of pipe to suction to keep submerged end under water.
Mechanical trouble and noise	1. Bent shaft and/or damaged bearings.	1. Take motor to authorized motor repair shop.
	2. Suction and/or discharge piping not properly supported and anchored.	2. See that all piping is supported to relieve strain on pump assembly.

## SPM SERIES HIGH POWER CENTRIFUGALS (For Pricing Refer To Repair Parts Price List)

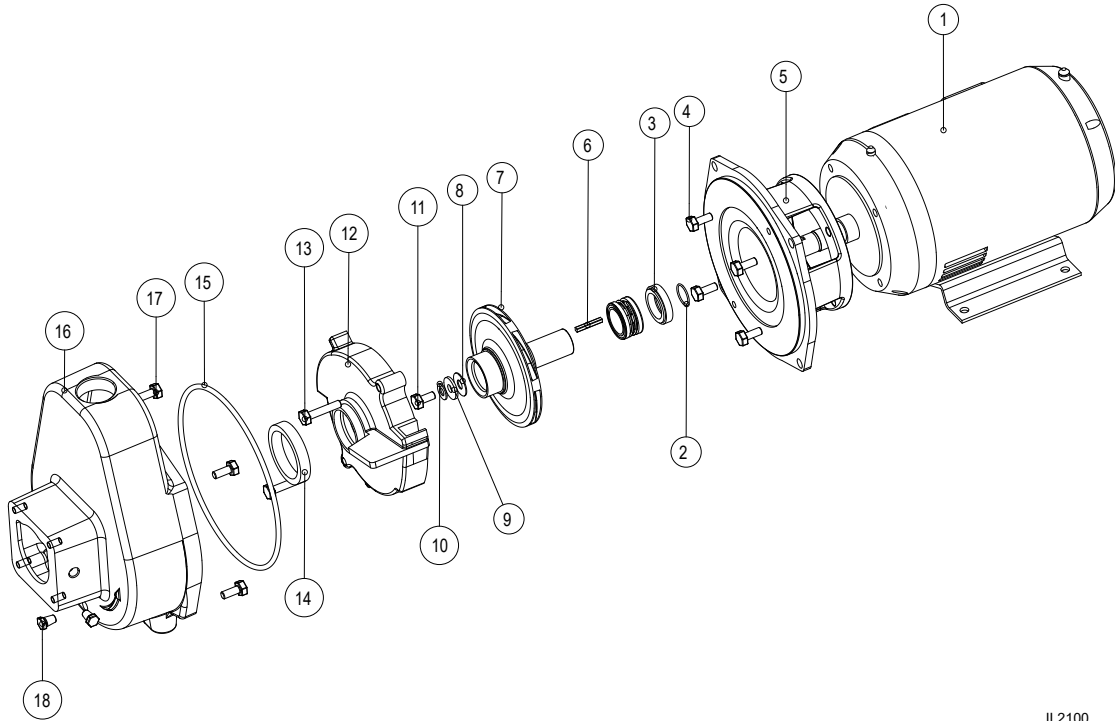

IL2100

ITEM	DESCRIPTION	QTY	3 HP 1 PH	3 HP 3 PH	5 HP 1 PH	5 HP 3 PH
			PART #	PART #	PART #	PART #
1	BALDOR MOTOR	1	134962	134965	134963	134966
2	O-RING, 1.00 x .07" THICKNESS	1	024893	024893	024893	024893
3	MECHANICAL SEAL, JOHN CRANE TYPE 2100, 1.25"	1	024901	024901	024901	024901
4	CAP SCREW, 3/8-16 x .875" LONG	4	*	*	*	*
5	MOUNTING RING	1	024898	024898	024898	024898
6	KEY BALDOR	1	025247	025247	025247	025247
7	IMPELLER	1	025245	025245	025246	025246
8	GASKET, OD 1.15", ID.45" x .03" THICKNESS	1	025501	025501	025501	025501
9	WASHER, OD1.125", ID.415" x .125" THICKNESS	1	024905	024905	024905	024905
10	GASKET, OD.66", ID.35" x .05" THICKNESS	1	025502	025502	025502	025502
11	CAP SCREW, 3/8-16 x .75" LONG	1	*	*	*	*
12	DIFFUSER w/WEAR RING	1	024908	024908	024908	024908
13	CAP SCREW, 3-16 x 1.75" LONG	2	*	*	*	*
14	DIFFUSER RING GASKET, OD 3.0", ID2.4" x .53" THICKNESS	1	024909	024909	024909	024909
15	GASKET, 8.84" X 0.23" THICKNESS	1	024899	024899	024899	024899
16	PUMP BODY	1	024910	024910	024911	024911
17	CAP SCREW, 3/8-16 x .875" LONG	4	*	*	*	*
18	PIPE PLUG, 1/4" NPT	2	024593	024593	024593	024593
order from catalog	SUCTION FLANGE KIT	1	024912	024912	024913	024913